

# SOLAR BEACON

## TOWER LIGHT



**IP66**  
RATING  
FOR DUST &  
WATER  
RESISTANCE

Warning beacon lights are a great way for sites to alert pedestrians and vehicles at key areas such as intersections where there may be poor visibility due to dust or surrounding environments. Earthsolar Beacon towers are built for extreme conditions with 2 ultra-bright red flashing light beacons on a 3-meter height pole.

The solar-powered Beacon tower needs no trenching for power lines making it easy and safer onsite. The tower has 5 days of autonomy with a 12 hrs/day runtime.

The high-quality monocrystalline solar panels are highly efficient in generating power to charge the battery. The Elion Lithium batteries included offer great performance in high temperatures on-site.

The Beacon Lights are positioned beneath the solar panel, meaning they are away from direct sunlight, while also making them easier and safer to access.



### 360° ROTATABLE SOLAR FRAME



- ✓ **Waterproof IP66 luminaires & IP68 Solar panels**
- ✓ **Elion Lithium battery power storage**
- ✓ **Monocrystalline grade#1 solar panel**
- ✓ **Powdercoated easy break-back pole**
- ✓ **5 days autonomy at 12hrs/day runtime**
- ✓ **Concrete base with forklift sleeves**
- ✓ **Operating switch at extended and adjustable arm**



**LEARN MORE**

# SPECIFICATIONS

## SOLAR BEACON TOWER LIGHT

<b>Code</b>	<b>ETG-01SB025</b>
Solar Panel	360 Monocrystalline
Autonomy	5 Days / 12 hrs runtime
IP Rating	IP68: Solar Panel   Cables Connectors & lockout switch
Light	Customisable
Light Colours	Customisable
Pole height (m)	3
Battery	Elion Lithium Battery

### **BEACON LIGHT** LED

This super bright beacon light has a durable PC Lens and has 360 degrees of coverage. Clearly visible even in harsh weather conditions such as fog, rain or snow.



# DIMENSIONS

## SOLAR BEACON TOWER LIGHT

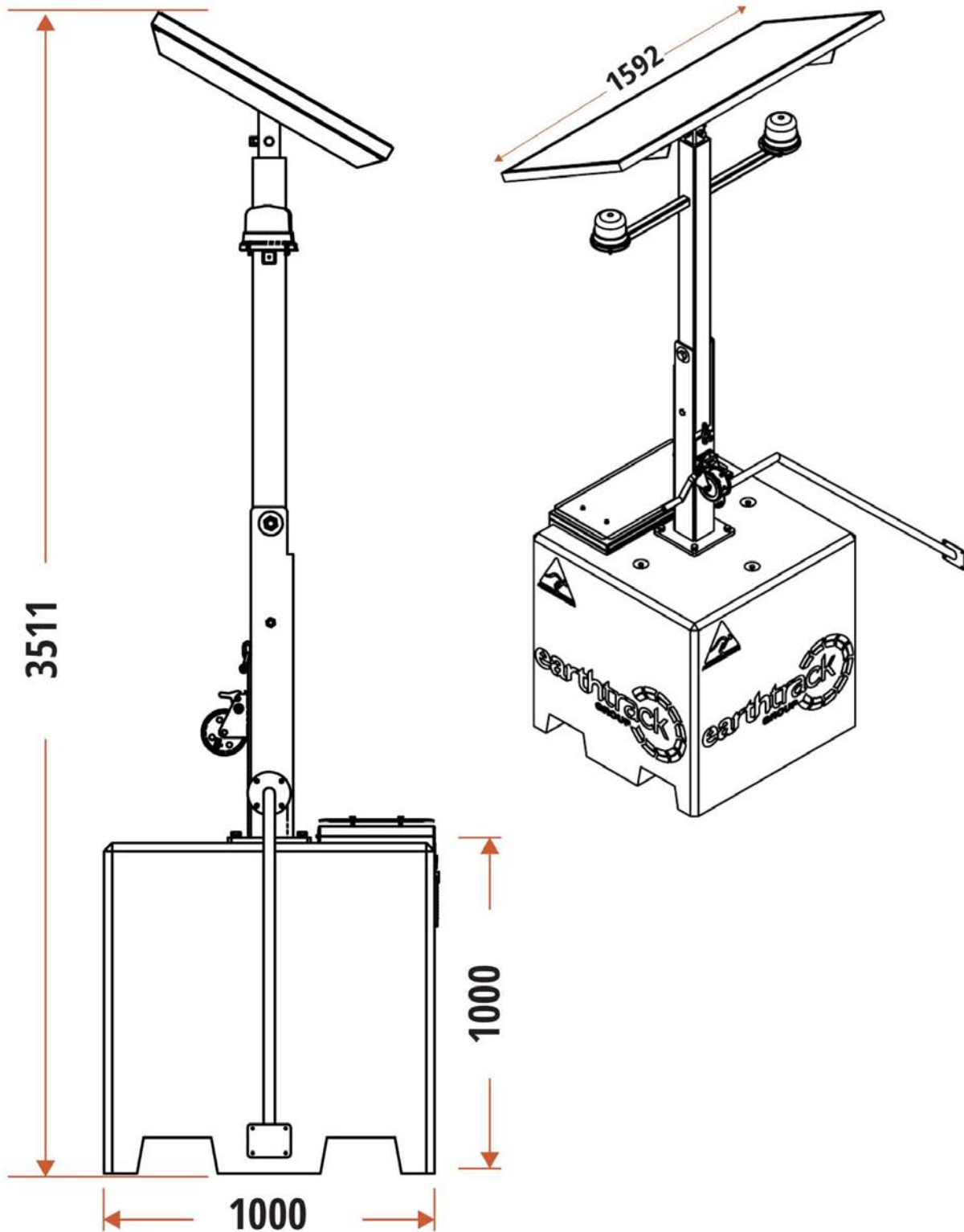



1300 410 485 | [sales@etms.com.au](mailto:sales@etms.com.au) | [www.etms.com.au](http://www.etms.com.au)

